



Microbubble Solutions for Aquaculture

High-Efficiency Aeration | Water Quality Enhancement

Strongco Trading Company Ltd

Breaking Tradition, Defining a New Standard for "Precision Water Exchange"

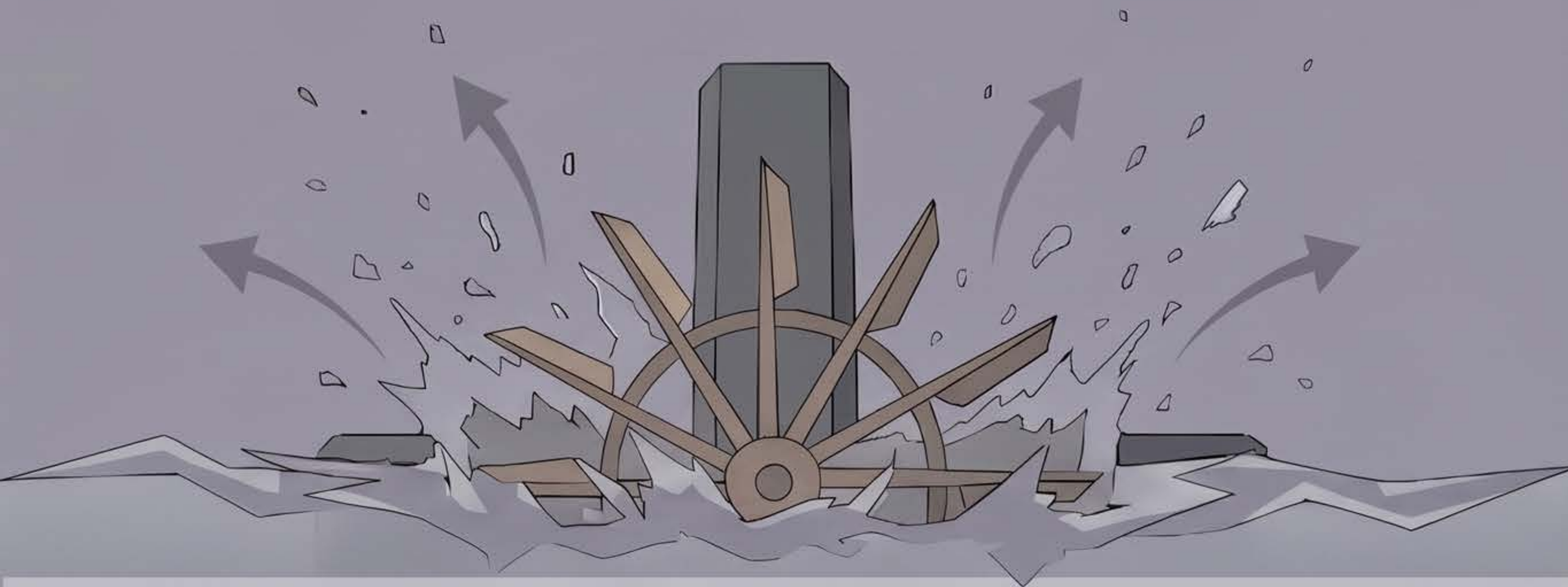

The Trouble with Traditional Waterwheels

- ⚠ Bubbles are too large, resulting in a short dissolved oxygen retention time.
- ⚠ Only stirs surface water, pond bottom still lacks oxygen.
- ⚠ Slow growth rate for fish and shrimp, reduced survival rate.
- ⚠ Mechanical equipment easily damaged, frequent maintenance needed.
- ⚠ Long operation required to maintain oxygen levels, high power consumption.
- ⚠ Pond bottom water turbid, rapid bacterial biofilm build-up.

Traditional Aeration — Surface Agitation, Energy Loss, Localized Oxygenation



Fills the Water

Precision Water Exchange — Probing the Core, Full Pond Coverage, Long-Acting Dissolved Oxygen 0.2~0.5 ppm

Traditional technologies only stir up a few small splashes, while we choose to go deeper to the core, converting every bit of electrical energy into the longest-acting dissolved oxygen value.

What Are Microbubbles?

Microbubbles are tiny air bubbles that stay in water for a long time, increasing dissolved oxygen.

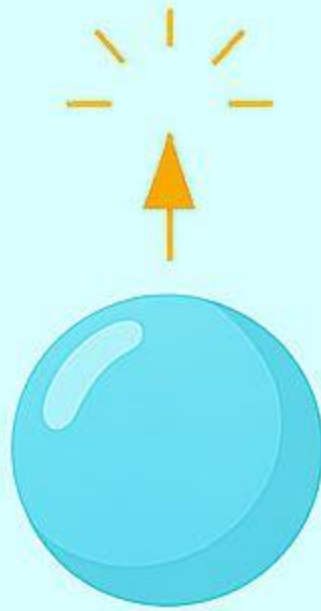

Large Bubbles

Rise quickly and burst at the surface.

> 0.1 mm



Microbubbles

Form and collapse within the water, creating localized heat and vibration waves.

10^{-4} m \sim 10^{-6} m

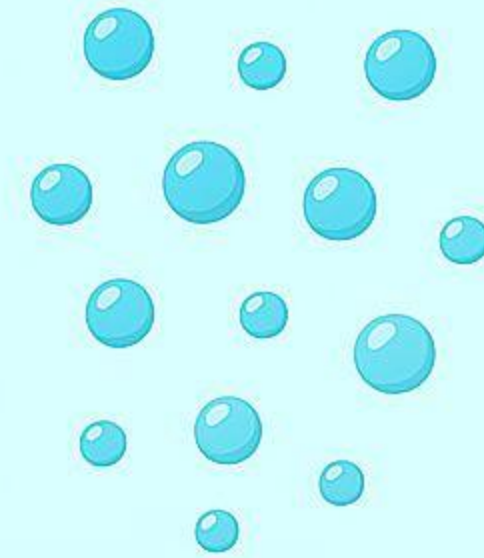

Ultrafine Bubbles

Remain suspended in water and move randomly (Brownian motion).

< 10^{-6} m

Smaller bubbles last longer and deliver oxygen more efficiently.

How Microbubbles Work

When microbubbles collapse in the water, they generate oxygen-free radicals that help eliminate bacteria.

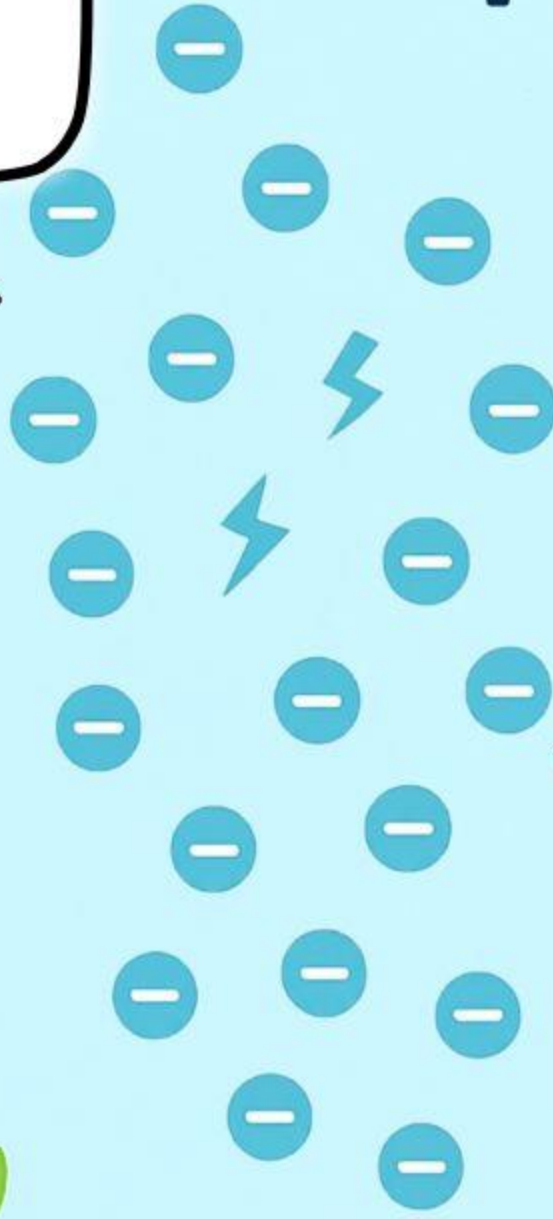

Microbubbles carry a strong negative charge, allowing them to attract positively charged dirt and residues for more effective cleaning.



Lift Away Impurities



Eliminate Bacteria



Sustained Oxygenation



Microbubbles

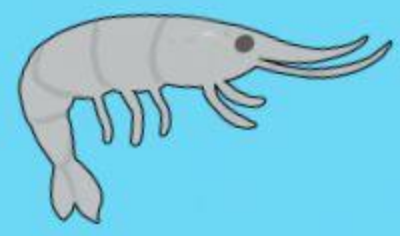
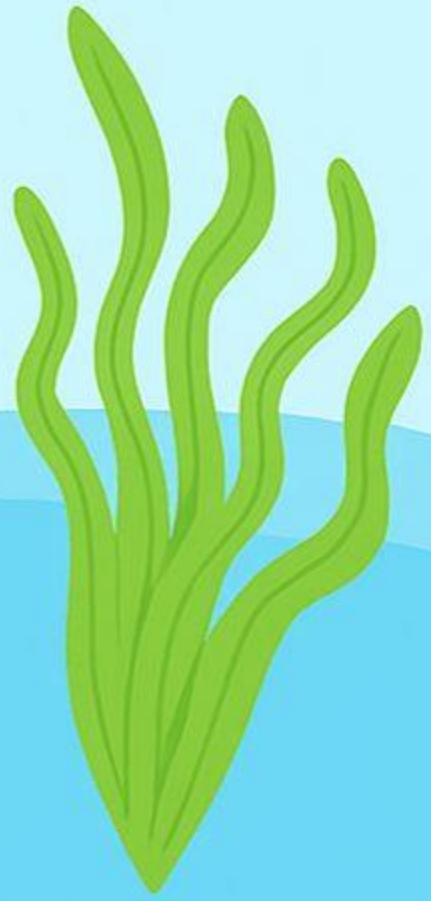

Micro-Nanobubbles Break Free from Gravity, Achieving 1.2m Full Water Column Coverage

Traditional Bubble Limitations

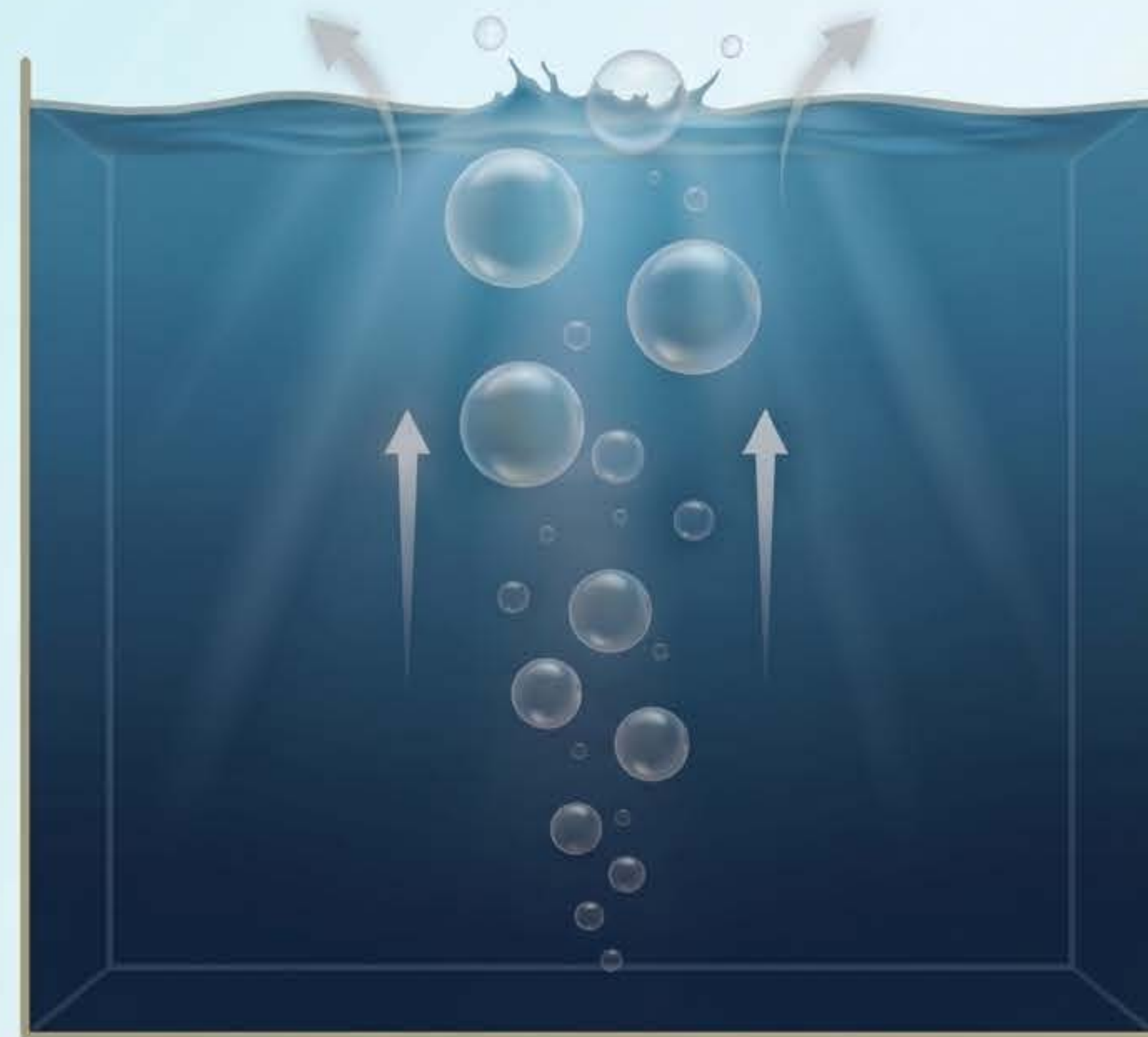

Large volume, strong buoyancy. Rise straight to the surface and burst within seconds, unable to remain in the bottom layer.

Advantages of Micro-Nanobubbles



Neutral Buoyancy & Brownian Motion: Extremely tiny bubbles, effectively unaffected by buoyancy. Physical, random motion (Brownian motion) enables active diffusion into the bottom dead corners of a 1.2m deep pond.

Full Water Column Uniform Temperature Convection: The slow diffusion of bubbles promotes deep water mixing and convection, completely eliminating the lethal stratification of "high surface temperature, low bottom oxygen".

AM248B Modular Aeration Architecture

Redefines Water Body Activation Standards



1. Air Intake Core



AI248B Front-mount Air Valve:
Installed at water inlet,
employs Venturi effect for
precise automatic air
suction.

2. Power Core



Daji TPH (4T6K) Pump:
Heart of the system,
provides extremely stable
dynamic water pressure
>2 bar.

3. Generation Core



**MB248S Micro-Nano Bubble
Generator:** Patented physical
turbulunce spray design, stably
produces high-concentration
milky-white micro-nano bubbles.



Venturi Tube Natural Aspiration Technology Eliminates the Need for High-Energy Air Pumps

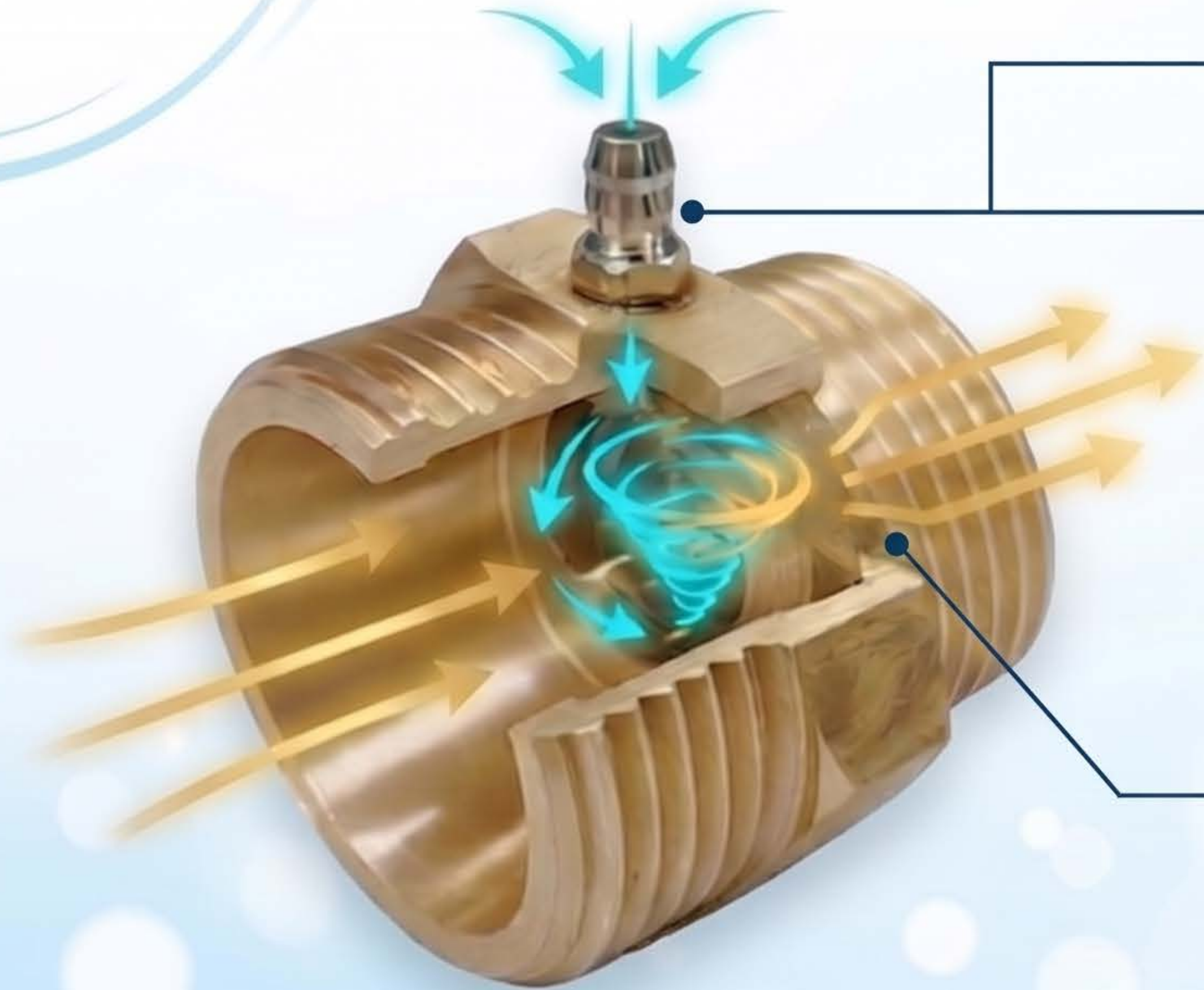

- **Zero Air Compressor Dependency**

Uses fluid kinetic energy from a water pump to generate negative pressure for automatic aspiration, saving construction and electricity costs for traditional high-energy air pumps.

- **Micron-level Precision Adjustment**

Precisely fine-tunes air-water ratio via intake valve, controlling intake at approx. 300 ml/min to ensure ultimate fineness of final bubbles.

- **Deep Water Counter-back Pressure Design**

Special structure ensures stable intake even in deep water operations, eliminating reliance on high-power forced air equipment.

Patented Physical Turbulence Design Achieves 120 Days of Continuous Anti-Clogging Operation



- **Physical Shear Atomization:**
Uses 'Positive-Negative Collision' strong fluid dynamics to instantly atomize gas, completely eliminating easily-worn-out motor-driven nozzles.
- **Ultimate Anti-Clogging Specification:**
Patented large-aperture design smoothly passes suspended impurities under 0.8mm, perfectly corresponding to the complete 100-105 day high-density aquaculture cycle, eliminating the risk of mid-cycle shutdowns for cleaning.
- **High-Throughput Performance:**
Single generator flow rate up to 0.7 tons/hour (requires 2 Bar or higher driving water pressure), providing the huge processing capacity needed for commercial scale.

Patented Technology Certification & Customized Modular Upgrade Solution

Patent No. 1870325

(AM248B Micro-Nanobubble Enhancement System)



Based on current water pump and fish pond specifications, we provide precise modular configurations and technical implementation.



Dual-Module Architecture, Seamlessly Integrated into Your Exclusive Setting

Solution A: Punch-Free External Hang-On System

 Specifically Designed for Below-Ground Ponds Without Drainage Holes

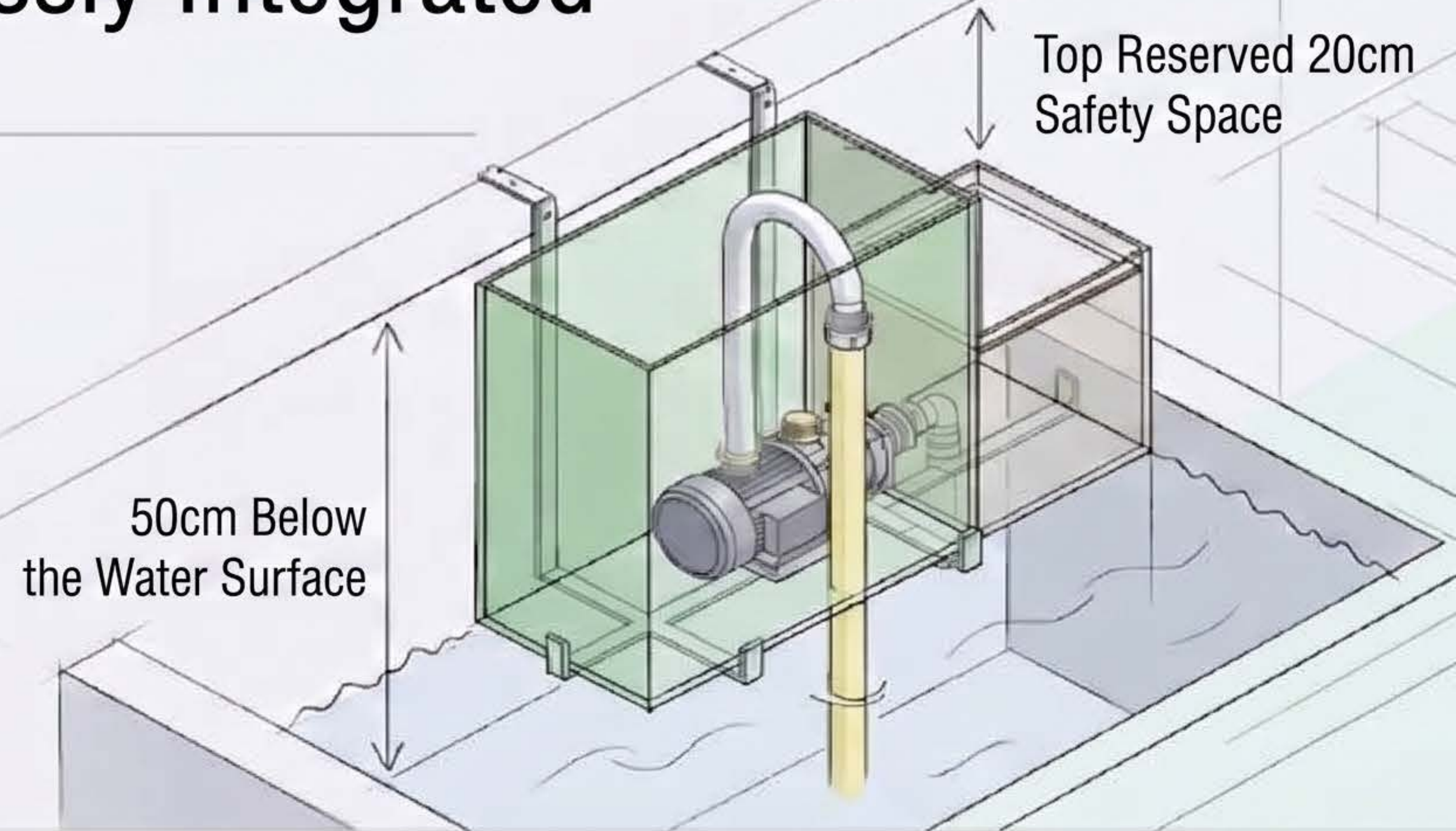

Solution B: Standard Direct-Connect System

Perfectly Mated to Existing Pipe Hole Locations, Maximizing Site Utilization

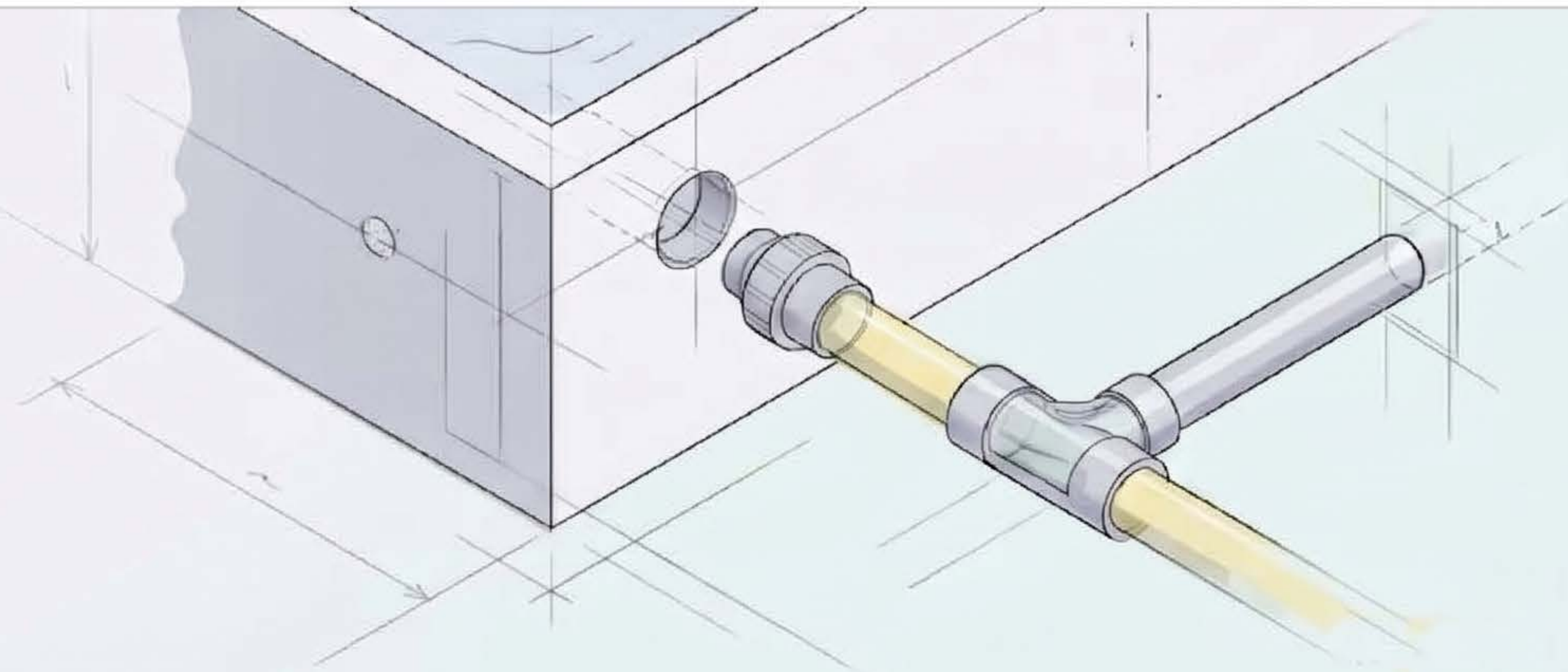

AM248B Micro-Bubble Aeration System - External Hang-on Type

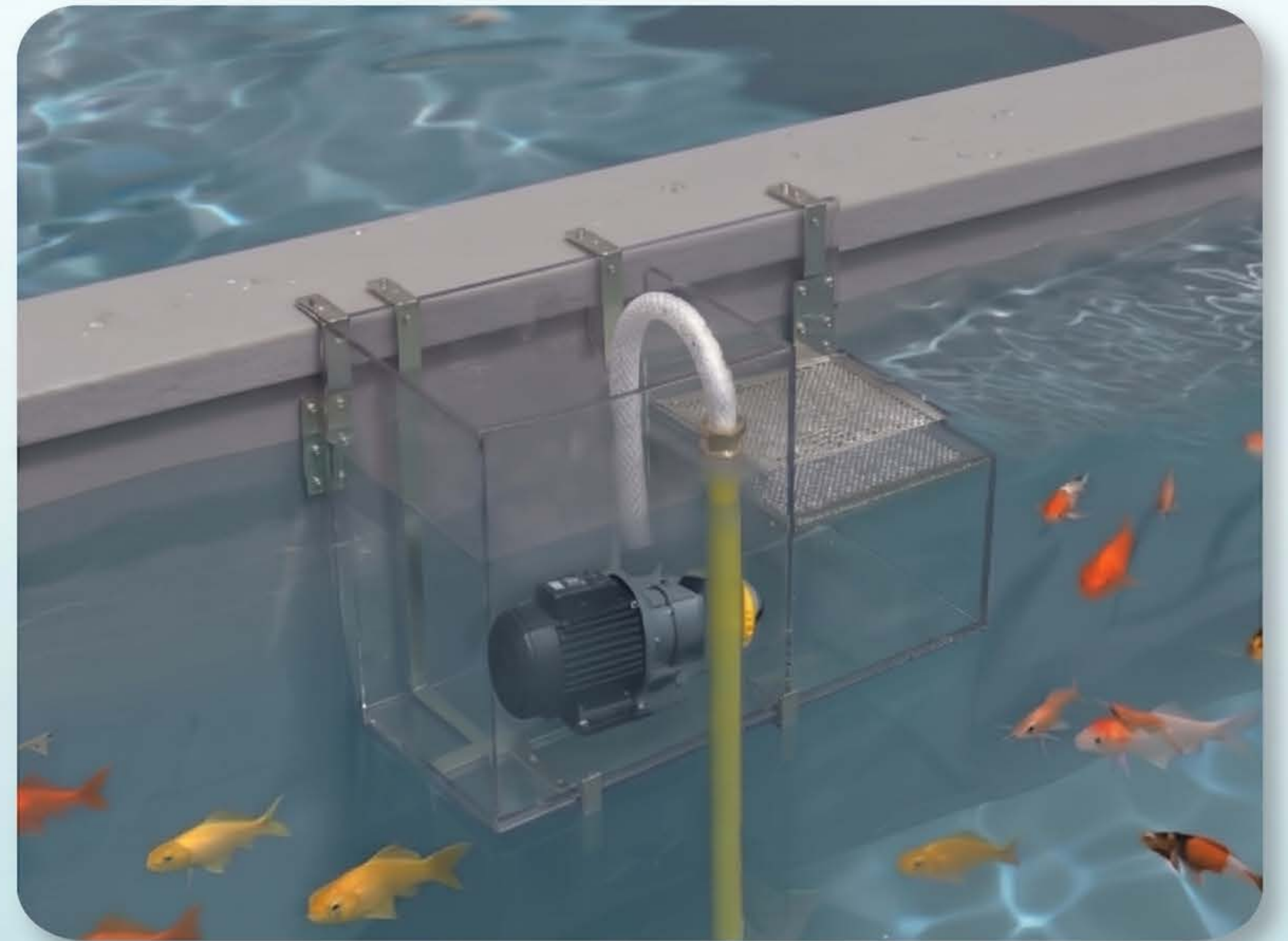
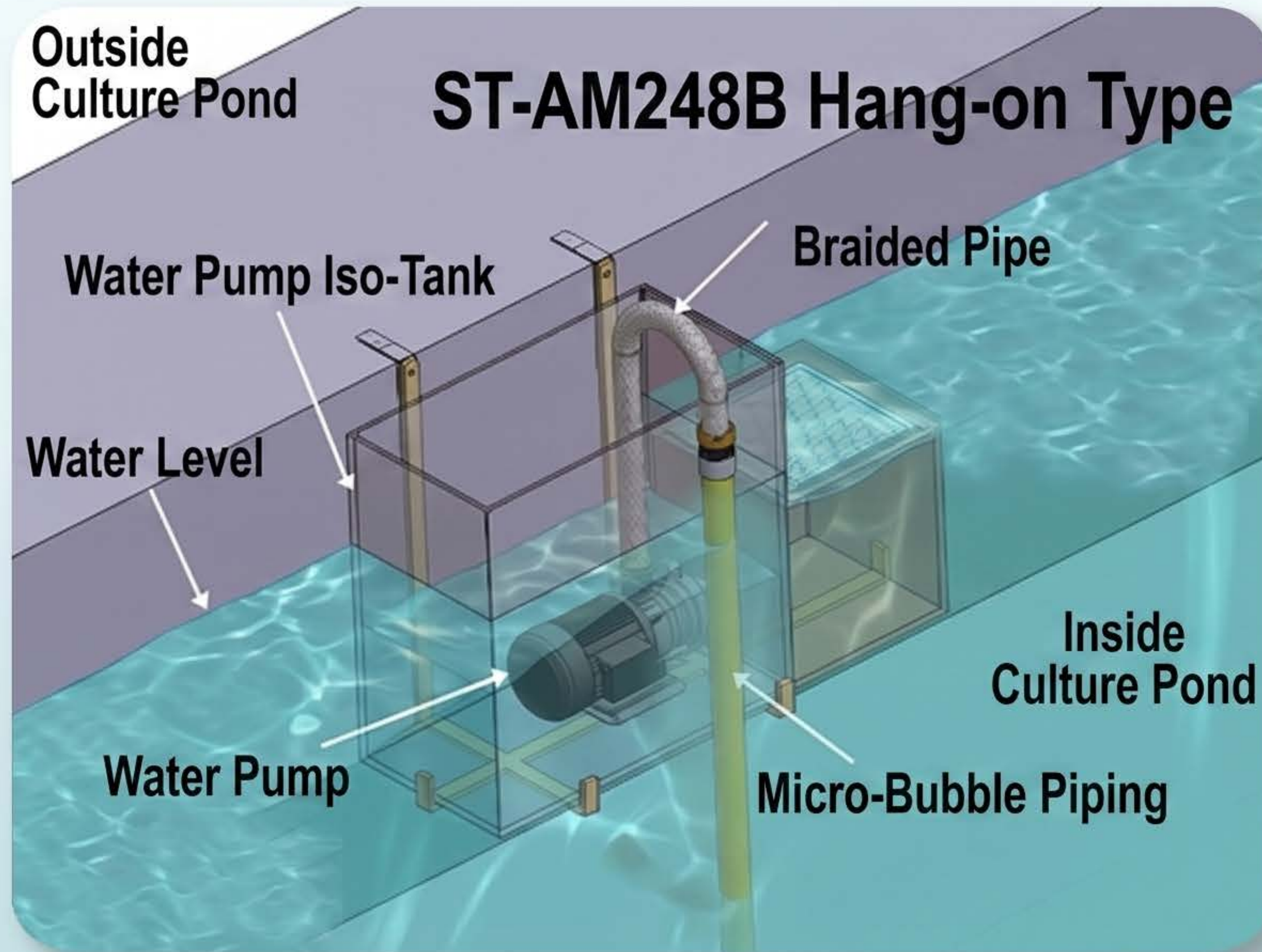

Exclusive Advantages for Fishery-PV Symbiosis

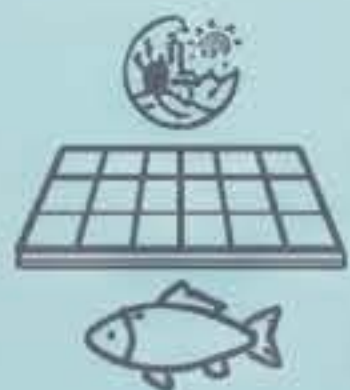

No Excavation / Pond Modification

(No changes to existing structure,
plug-and-play)



High Dissolved Oxygen Efficiency

(Solves low DO survival issues
caused by shading)



Smart Monitoring Integration

(Integrates with automated
green energy systems)



Preferred for
Green Aquaculture

Watch Simulation
Video



1

CORE DOCKING

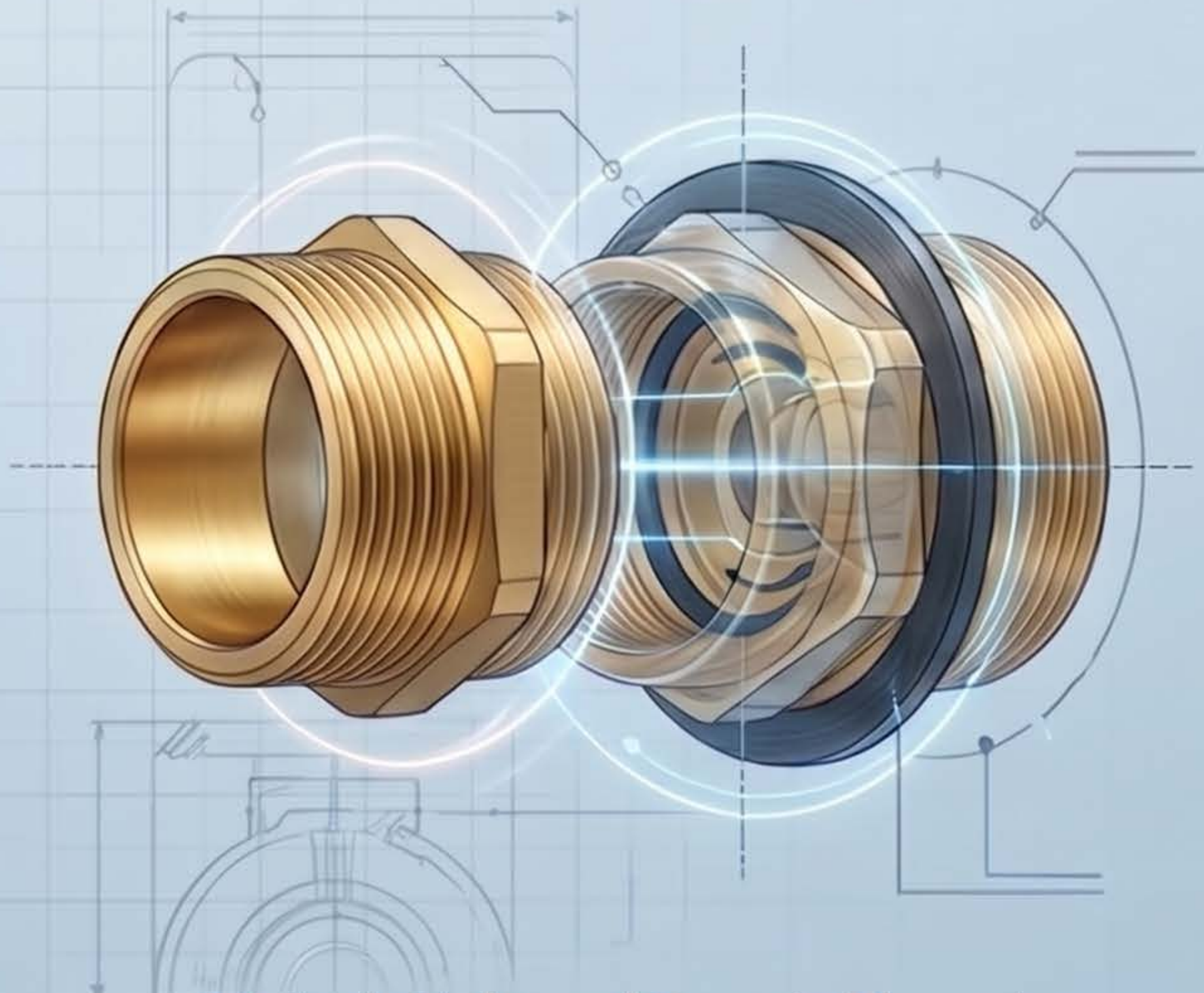

1.2-inch Male and Female Thread Precision Engagement, Constructing a Protective Foundation.

2

DOUBLE SEALING

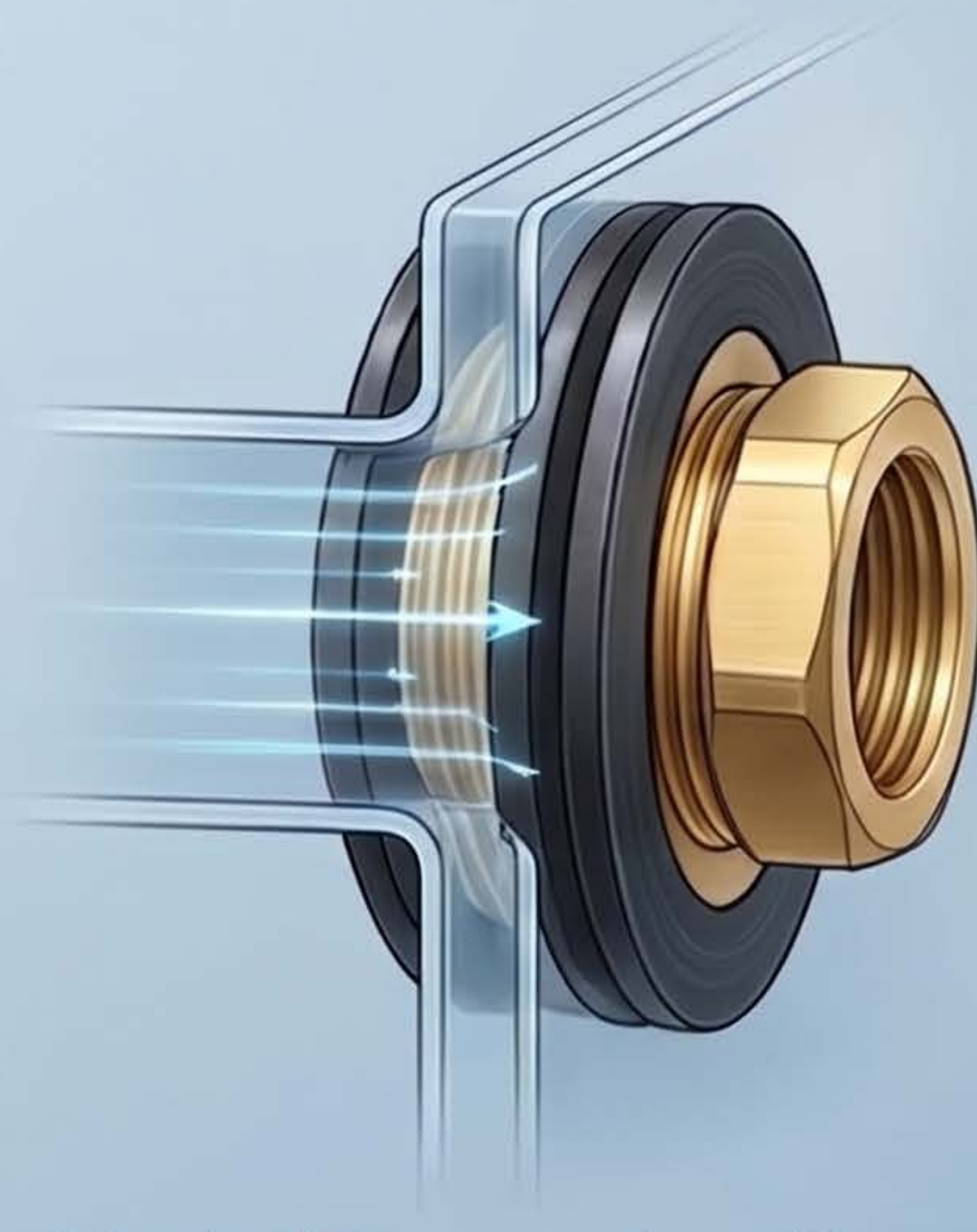

Physical Compression of Inner and Outer Wall Dual Gaskets, Creating a Completely Dry, Safe Space.

3

WATER FLOW PATH INSURANCE

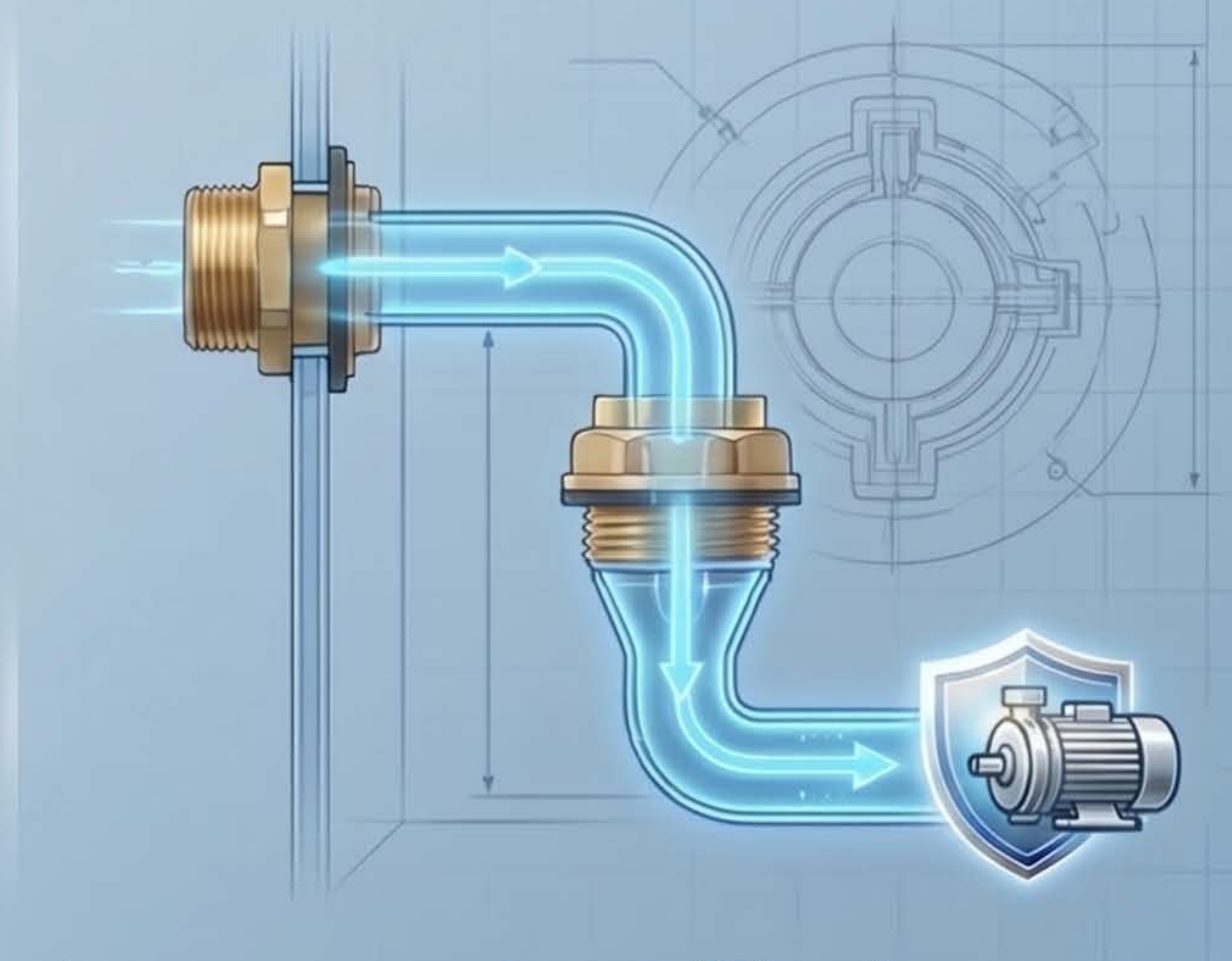

Patented Diversion, Completely Eliminating High Water Level Dry-Run Risk.

**BID FAREWELL TO LEAKAGE CONCERNS,
WELCOME THE NEW STANDARD IN SMART PROTECTION.**

Ultimate Application of Micro-Vortex Technology: Global Fluid Topology

1. Flow Guidance

Smoothly guided to the pond center by the L-elbow

2. Distribution

A 5-way fitting establishes a cross-shaped balanced power structure

3. Extension

4 main headers smoothly deliver kinetic energy to all four corners of the pond

Complete Area Coverage, No Dead Zones

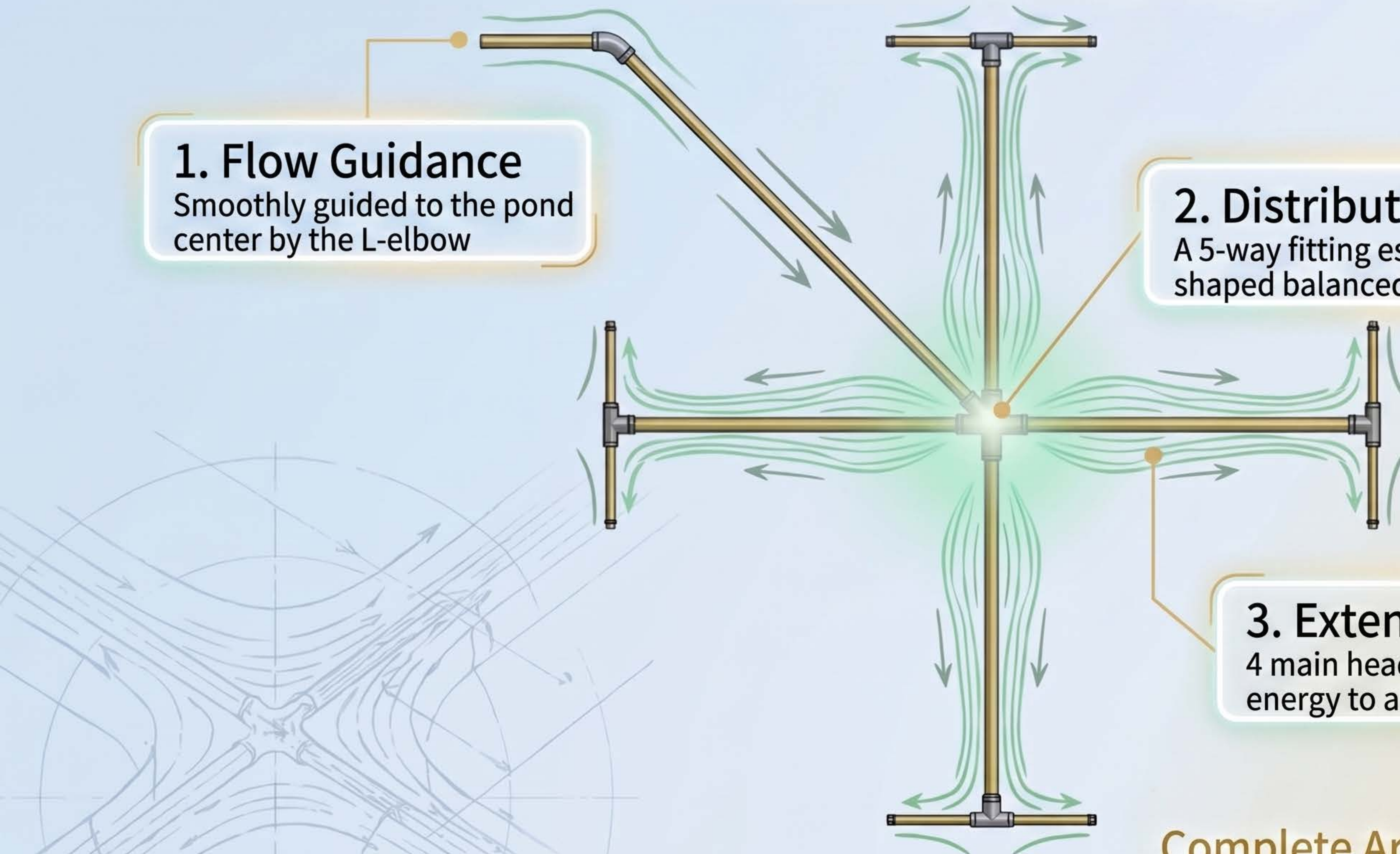

“Cross-Flow, End Release. Stays Longer, Absorbs More.”

 **High-Pressure Flow
Divergence Zone**



Diameter < 50 μm

Releases micro-bubbles
finer than hair

**Residence Time
Extended 3x**

Rises slowly in water, maximizing
air-water contact area

Rapidly Purify Water Quality and Significantly Optimize Feed Conversion Ratio (FCR)

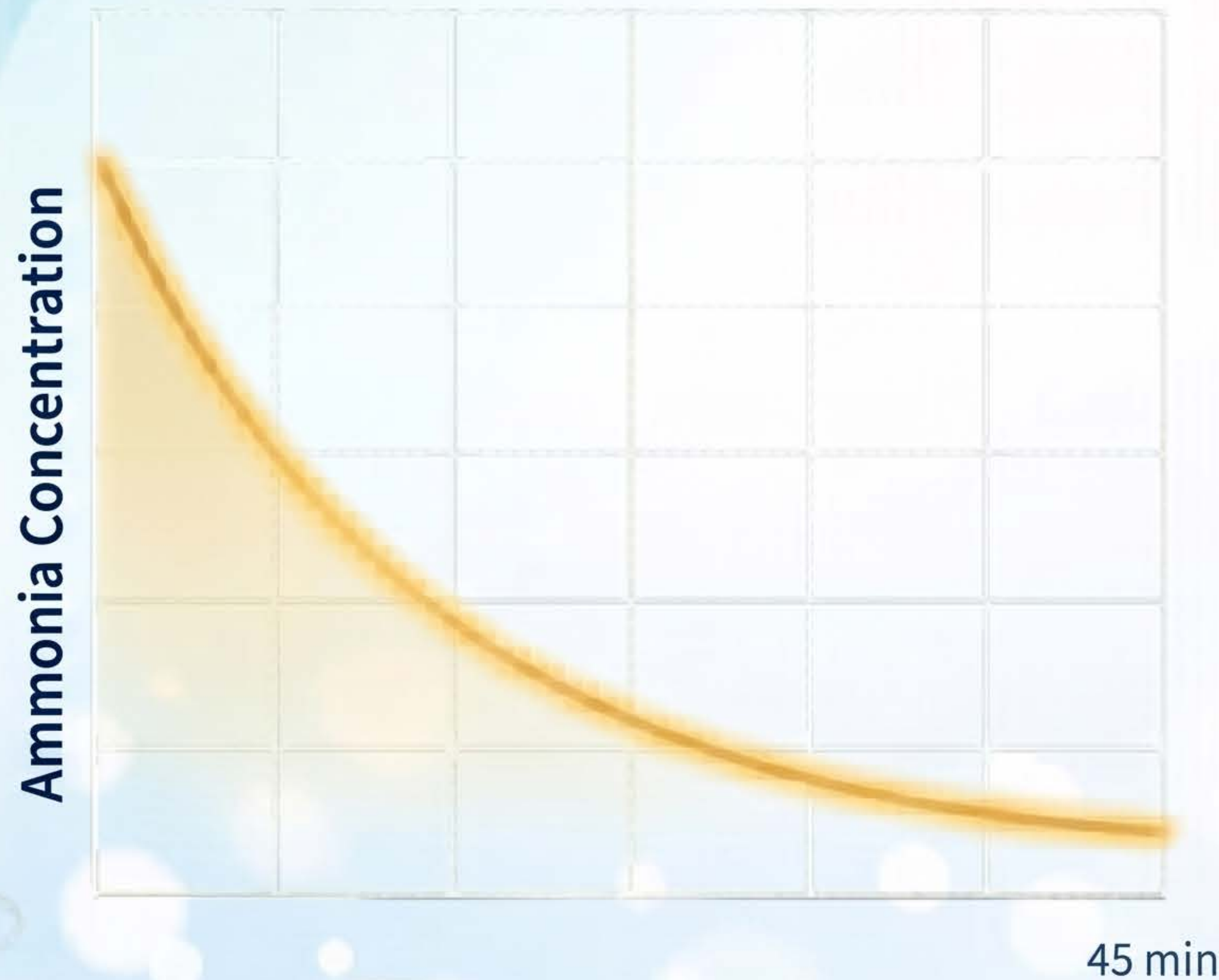

Toxin Removal

Measured results show 70-80% ammonia-nitrogen removal achieved within 45 minutes, effectively preventing algae crash crises and sudden water quality changes.

Dissolved Oxygen Saturation

Elevates vast water bodies to near 100% dissolved oxygen saturation within 1-1.5 hours of activation.

FCR Optimization

Abundant and stable bottom-level dissolved oxygen significantly reduces the white shrimp's metabolic burden, enhancing feed absorption. Precisely controls feed expenditures, accounting for approximately 40% of total operating costs.

Hydroxyl Free Radicals ($\cdot\text{OH}$) Provision-Free Physical Biosecurity Protection

PHYSICAL STERILIZATION

When micro-nanobubbles collapse and burst in water, they instantly produce reactive oxygen species (ROS) and hydroxyl free radicals ($\cdot\text{OH}$), physically neutralizing 100% of *Vibrio parahaemolyticus* within minutes.



IMMUNITY ENHANCEMENT

The system maintains a year-round high dissolved oxygen environment of 6-8 mg/L, maximize reinforcing white shrimp's auto-immunity and survival rate during fragile molting periods.

GREEN ESG VALUE

Through stable water quality, increased dissolved oxygen, and reduced medication needs, the Fishery-PV Symbiosis system further minimizes environmental impact, strengthening the overall value of high-quality, sustainable aquaculture.

Growth Cycle Reduction Drives Exponential Annual Total Production Growth



Dual-Effect Compound Gain

High Dissolved Oxygen and pure water quality boost white shrimp growth rate by 15%, and significantly increase survival rate by 20%.

Farming Cycle Compression

The standard farming duration per batch is drastically reduced from 120 days to approximately 100-105 days for harvest maturity.

Batch Turnover Maximization

The total annual harvest batches are breakthrough-increased from 3 to 3.58, maximizing production capacity and asset turnover under the same infrastructure.

Advanced Materials and Design Architecture Establish an Impenetrable Technical Barrier

AM248B System

Traditional System

Material Science

Industrial-grade anti-ozone PP material, extremely corrosion-resistant.

Rubber microporous tube, highly susceptible to oxidation and embrittlement, releasing microplastic pollution into the water.

Nozzle Design
(Design Logic)

Physical turbulence large-orifice design, completely solves biofilm adhesion and clogging issues.

Micro-sized pores are very easily completely clogged by aquatic biofilms and impurities, leading to abnormal air pressure.

Intake Mechanism

Venturi tube natural intake, high energy efficiency, zero risk of air compressor failure.

Forced aeration, extremely high energy consumption and cumbersome air compressor maintenance.

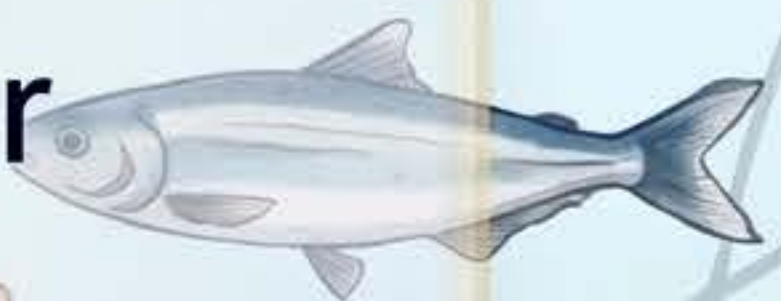
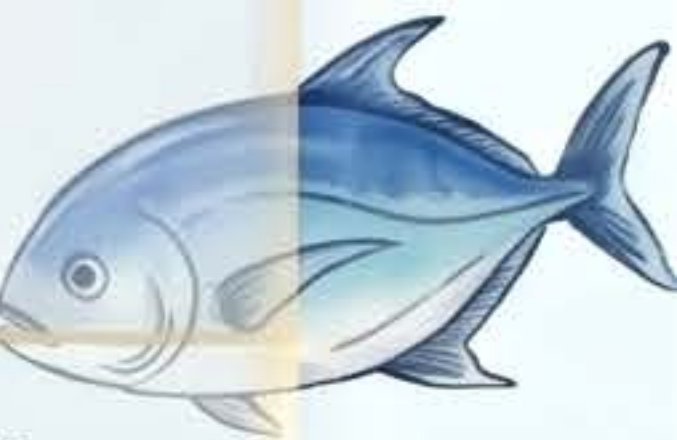

Significantly Reduce Operating Costs and Achieve Rapid Equipment Cost Recovery

Annual Electricity Cost Savings

Each single unit can achieve substantial savings of NT\$ 68,677 to NT\$ 217,686 in actual electricity costs per year (replacing high-consumption waterwheels and air compressors).

Maintenance Costs Plummet

By discarding complex mechanical structures and micro-porous tubes prone to clogging, annual equipment maintenance expenditure is significantly reduced by 40%.

Cuts in Epidemic Prevention Spending

Relying on physical sterilization, the cost of chemical agents and epidemic prevention consumables is significantly reduced by 30-50%.

Rapid Equipment Cost Recovery

The amount of annual net electricity cost savings generated by the system can directly offset or even exceed the initial purchase cost (CAPEX) of the new equipment.

Foresee a Bountiful Harvest, Master Total Environmental Control



[Operations]

High Water Exchange Rate
+
Low Energy Consumption
=
Optimized
Operating Cost

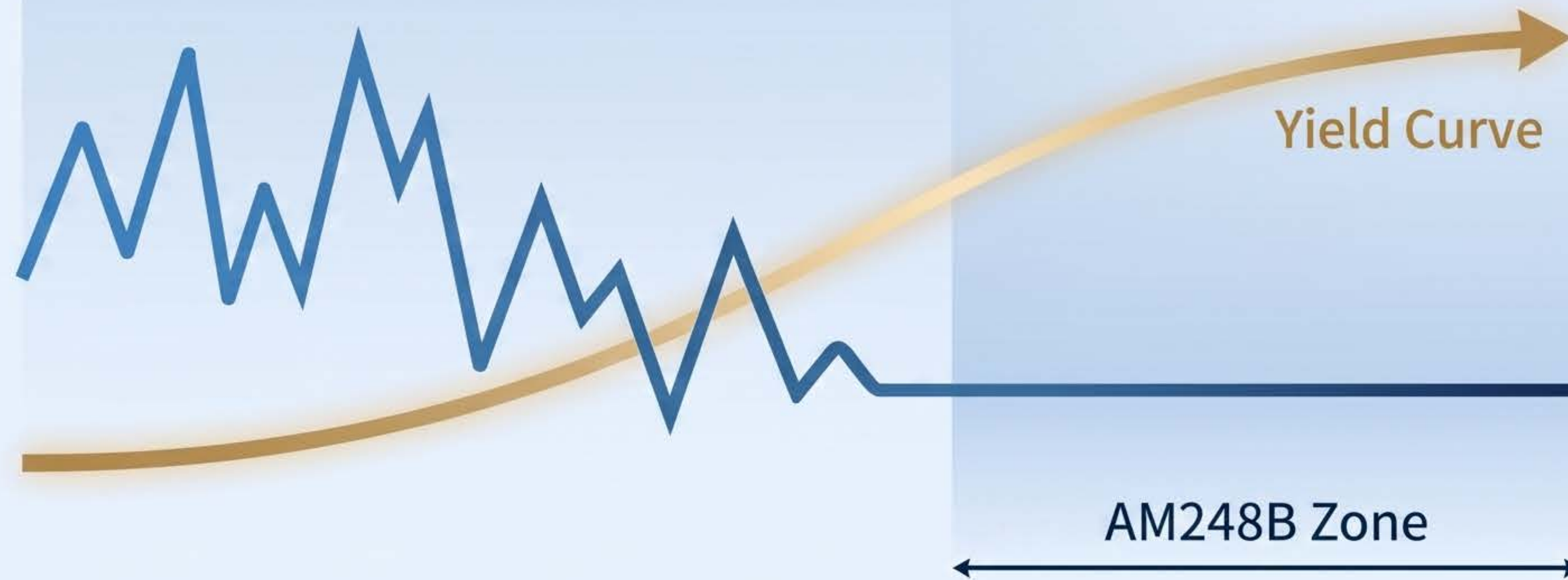

[Aquafarming]

Maximized Survival Space
+
Improved Growth Rate
=
Guaranteed
Bountiful Harvest

"In the area of aquavoltaics, stability is the highest-efficiency investment."

Start immediately, your smart aquaculture upgrade



Residential



Aquaculture



Industrial



LINE: @tfu4534l (lowercase L)

ERDEN

From residential to industrial, ERDEN provides the most micro-bubble solution. By harnessing technology, we inject endless vitality into your aquaculture business.

ERDEN Contact Info:

 @tfu4534l
 Address: No. 82, Sec. 2, Minzu Rd.,
Tanzi Dist., Taichung City, Taiwan
 Tel: +886-4-2531-2575 / +886-4-2534-4586

ERDEN, Injecting intelligence into water, creating value for you.